

Q.1 – Q.20 carry one mark each

1. You have gone to a cyber-cafe with a friend. You found that the cyber-café has only three terminals. All terminals are unoccupied. You and your friend have to make a random choice of selecting a terminal. What is the probability that both of you will NOT select the same terminal?

- (A) $\frac{1}{9}$ (C) $\frac{2}{3}$
 (B) $\frac{1}{3}$ (D) 1

2. Probability density function $p(x)$ of a random variable x is as shown below. The value of α is

- (A) $\frac{2}{c}$
 (B) $\frac{1}{c}$
 (C) $\frac{2}{(b+c)}$
 (D) $\frac{1}{(b+c)}$

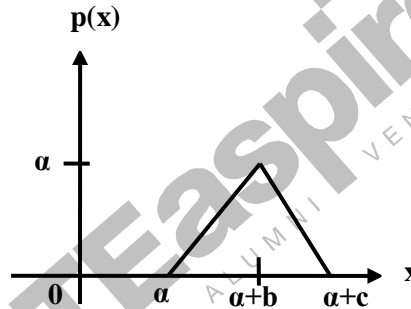

3. A linear ordinary differential equation is given as

$$\frac{d^2 y}{dt^2} + 3 \frac{dy}{dt} + 2y = \delta(t)$$

where $\delta(t)$ is an impulse input. The solution is found by Euler's forward-difference method that uses an integration step h . What is a suitable value of h ?

- (A) 2.0 (C) 1.0
 (B) 1.5 (D) 0.2

4. A $4 \text{ k}\Omega$, 0.02 W potentiometer is used in the circuit shown below. The minimum value of the resistance R_s in order to protect the potentiometer is

- (A) $2.23 \text{ k}\Omega$
 (B) $2.71 \text{ k}\Omega$
 (C) $3.82 \text{ k}\Omega$
 (D) $8.92 \text{ k}\Omega$

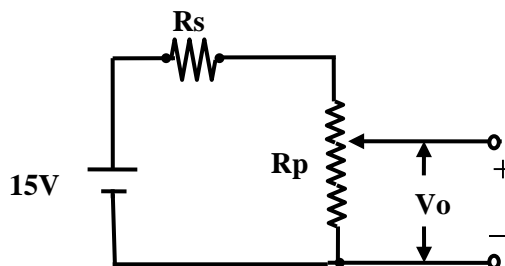

5. The root-mean-square value of a voltage waveform consisting of a superimposition of 2 V dc and a 4 V peak-to-peak square wave is
- (A) 2 V
 (B) $\sqrt{6}$ V
 (C) $\sqrt{8}$ V
 (D) $\sqrt{12}$ V
6. “Vena Contracta” is the cross section where the flow area is a minimum for a restriction type flowmeter. For an orifice meter, if d is the diameter of the orifice opening, then the area of the vena contracta is approximately
- (A) $\frac{\pi d^2}{4}$
 (B) $\frac{0.99\pi d^2}{4}$
 (C) $\frac{0.8\pi d^2}{4}$
 (D) $\frac{0.6\pi d^2}{4}$
7. A type J (iron-constantan) thermocouple has a voltage sensitivity of $55 \mu\text{V}/^\circ\text{C}$. A digital voltmeter (DVM) is used to measure the voltage under the condition shown in the following figure.

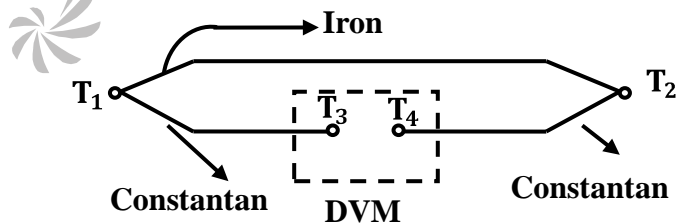

- Given that $T_1 = 300^\circ\text{C}$, $T_2 = 100^\circ\text{C}$ and $T_3 = T_4 = 20^\circ\text{C}$, the meter will indicate a voltage of
- (A) 11.0 mV
 (B) 15.4 mV
 (C) 16.5 mV
 (D) 17.6 mV

8. If the value of the resistance R in the following figure is increased by 50%, then voltage gain of the amplifier shown in the figure will change by

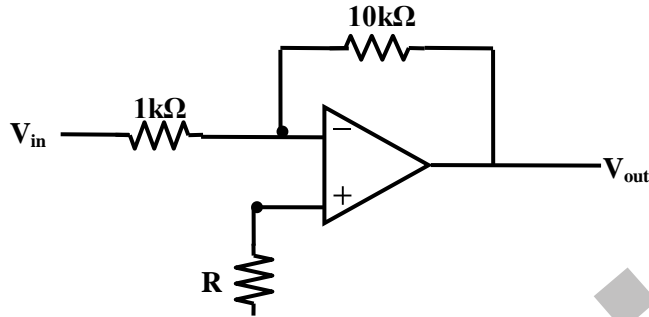

- (A) 50%
 (B) 5%
 (C) -50%
 (D) negligible amount
9. When the switch S_2 is closed the gain of the programmable gain amplifier shown in the following Figure is

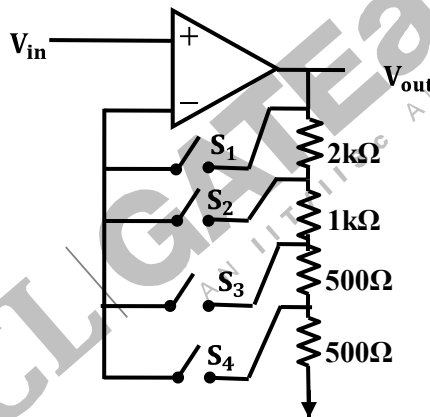

- (A) 0.5
 (B) 2
 (C) 4
 (D) 8
10. A memory mapped I/O device has an address of 00F0H. Which of the following 8085 instructions outputs the content of the accumulator to the I/O device?
- (A) LXI H, 00F0H
 MOV M, A
 (B) LXI H, 00F0H
 OUT M
 (C) LXI H, 00F0H
 OUT F0H
 (D) LXI H, 00F0H
 MOV A, M

11. A voltmeter has a range of [4 V, 20 V] and a resolution of 1 mV. The dynamic range is
- (A) 24 dB
 (B) 60 dB
 (C) 72 dB
 (D) 84 dB

12. A shielded cable is used for signal transmission between two instruments kept some distance apart. The shield should be
 (A) Left open at both ends
 (B) Grounded at one end
 (C) Grounded at both ends
 (D) Connected to ground at both ends using a resistance equal to the characteristic resistance of the cable

13. Compared to a conventional two-phase induction motor, a two-phase servomotor has

- (A) A smaller $\frac{R}{X}$ ratio and a lighter rotor
 (B) the same $\frac{R}{X}$ ratio and a heavier rotor
 (C) a larger $\frac{R}{X}$ ratio and a heavier rotor
 (D) a larger $\frac{R}{X}$ ratio and a lighter rotor

14. The state-variable representation of a plant is given by

$$\dot{x} = Ax + Bu$$

$$y = Cx.$$

where x is the state, u is the input and y is the output. Assuming zero initial condition, the impulse response of the plant is given by

- (A) $\exp(At)$
 (B) $\int \exp[A(t - \tau)] Bu(\tau) d\tau$
 (C) $C \exp(At) B$
 (D) $C \int \exp[A(t - \tau)] Bu(\tau) d\tau$

15. Correct input-output characteristic curve of a semiconductor laser is

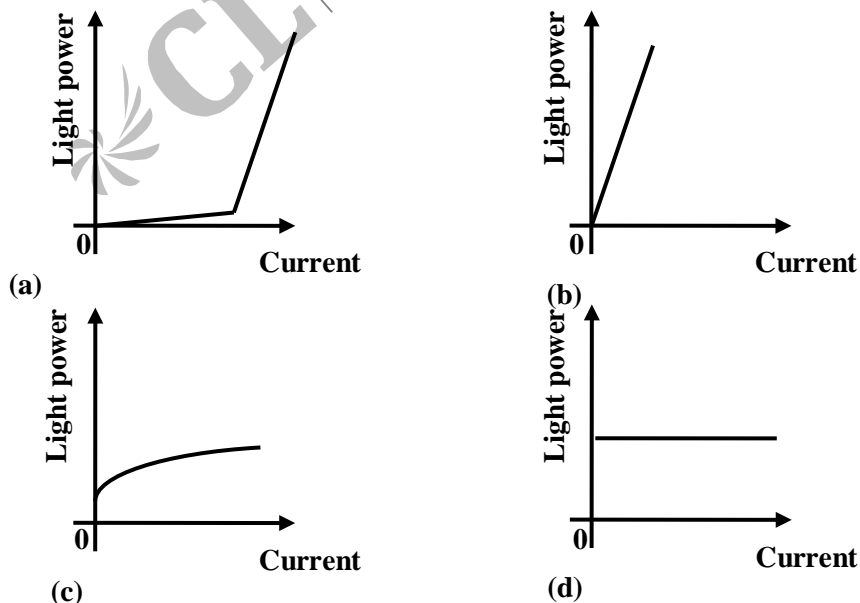

16. In a fiber optic displacement sensor shown in the following figure, the ratio of the output light intensity DOES NOT depend on

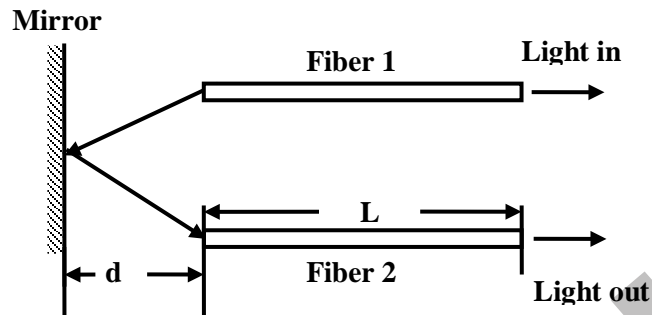

- (A) Numerical aperture of the fibers
 (B) Length L of the fibers
 (C) Distance d
 (D) Reflectivity of the mirror
17. For bio-potential recording, the impedance of an Ag/AgCl electrode, as compared to that of an Ag electrode of the same size, is
- (A) lower at all frequencies
 (B) lower for frequencies less than 10 Hz and higher for frequencies greater than 300 Hz
 (C) higher for frequencies less than 10 Hz and lower for frequencies greater than 300 Hz
 (D) higher at all frequencies
18. Collimated light beams from a He–Ne laser and a Sodium vapour lamp (used for street lighting) are focused using a lens. The size of the spot at the focal point due to the laser is relatively smaller because
- (A) laser light is relatively more monochromatic
 (B) the limiting divergence of laser light is relatively smaller
 (C) the output power of the laser is relatively larger
 (D) the wavelength of the laser is relatively longer
19. An X-ray source radiates two characteristic wavelengths : λ_1 and λ_2 , where $\lambda_1 < \lambda_2$. The shorter wavelength can be filtered out by passing the radiation through
- (A) a narrow slit
 (B) an interference filter
 (C) a crystalline material whose absorption edge lies between λ_1 and λ_2
 (D) a polarizer that rotates the polarization state of radiation at λ_2
20. A Pirani gage measures vacuum pressure and works on the principle of
- (A) change in ionizing potential
 (B) change in thermal conductivity
 (C) deformation of elastic body
 (D) change in self-inductance

Q.21 to Q.75 carry two marks each

21. Two dices are rolled simultaneously. The probability that the sum of digits on the top surface of the two dices is even, is

- (A) 0.5 (C) 0.167
(B) 0.25 (D) 0.125

22. The plot of a function $f(x)$ is shown in the following figure. A possible expression for the function $f(x)$ is

- (A) $\exp(|x|)$ (C) $\exp(-x)$
(B) $\exp\left(\frac{-1}{x}\right)$ (D) $\exp\left(\frac{1}{x}\right)$

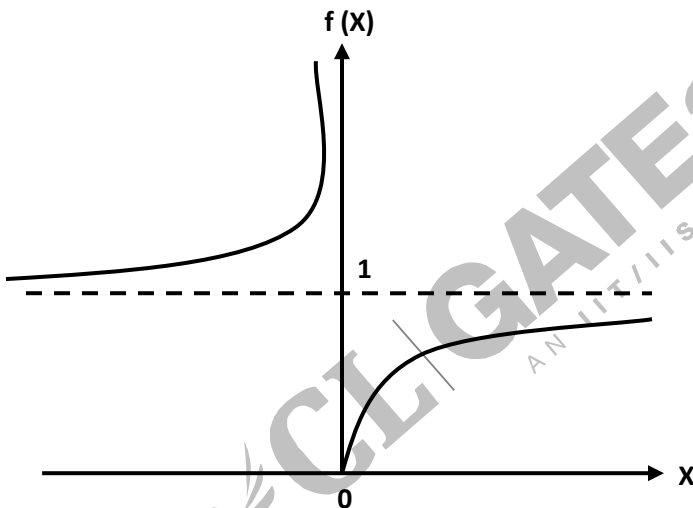

23. For a given 2×2 matrix A , it is observed that

$$A \begin{bmatrix} 1 \\ -1 \end{bmatrix} = - \begin{bmatrix} 1 \\ -1 \end{bmatrix} \text{ and } A \begin{bmatrix} 1 \\ -2 \end{bmatrix} = -2 \begin{bmatrix} 1 \\ -2 \end{bmatrix}$$

Then matrix A is

- (A) $A = \begin{bmatrix} 2 & 1 \\ -1 & -1 \end{bmatrix} \begin{bmatrix} -1 & 0 \\ 0 & -2 \end{bmatrix} \begin{bmatrix} 1 & 1 \\ -1 & -2 \end{bmatrix}$
(B) $A = \begin{bmatrix} 1 & 1 \\ -1 & -2 \end{bmatrix} \begin{bmatrix} 1 & 0 \\ 0 & 2 \end{bmatrix} \begin{bmatrix} 2 & 1 \\ -1 & -1 \end{bmatrix}$

$$(C) A = \begin{bmatrix} 1 & 1 \\ -1 & -2 \end{bmatrix} \begin{bmatrix} -1 & 0 \\ 0 & -2 \end{bmatrix} \begin{bmatrix} 2 & 1 \\ -1 & -1 \end{bmatrix}$$

$$(D) A = \begin{bmatrix} 0 & -2 \\ 1 & -3 \end{bmatrix}$$

24. For an initial value problem $\ddot{y} + 2\dot{y} + 101y = 10.4e^x$, $y(0) = 1.1$ and $\dot{y} = -0.9$. Various solutions are written in the following groups. Match the type of solution with the correct expression.

Group 1

Group 2

P. General solution of homogeneous equations

$$1.0.1e^x$$

Q. Particular integral

$$2.e^{-x} (A \cos 10x + B \sin 10x)$$

R. Total solution satisfying boundary conditions

$$3.e^{-x} \cos 10x + 0.1e^x$$

(A) P-2, Q-1, R-3

(C) P-1, Q-2, R-3

(B) P-1, Q-3, R-2

(D) P-3, Q-2, R-1

25. The value of the integral of the complex function

$$f(s) = \frac{3s+4}{(s+1)(s+2)}$$

Along the path $|s| = 3$ is

(A) $2\pi j$

(C) $6\pi j$

(B) $4\pi j$

(D) $8\pi j$

26. For $k = 0, 1, 2, \dots$, the steps of Newton-Raphson method for solving a non-linear equation is given as

$$x_{k+1} = \frac{2}{3}x_k + \frac{5}{3}x_k^{-2}$$

Starting from a suitable initial choice as k tends to ∞ , the iterate x_k tends to

(A) 1.7099

(C) 3.1251

(B) 2.2361

(D) 5.0000

27. The function $y = \sin \phi$, ($\phi > 0$) is approximated as $y = \phi$, where ϕ is in radian. The maximum value of ϕ for which the error due to the approximation is within $\pm 2\%$ is

(A) 0.1 rad

(C) 0.3 rad

(B) 0.2 rad

(D) 0.4 rad

28. A certain quantity x is calculated from measured values of a , b , and c using the formula,

$$x = k \frac{a^2}{b - c}$$

where k is a constant. The maximum limiting error in each of the three measured quantities is Δ . The maximum limiting error in x will be

- (A) $2 \left(\left| \frac{1}{a} \right| + \left| \frac{1}{b - c} \right| \right) |x| \Delta$
- (B) $\left(\left| \frac{1}{a} \right| + \left| \frac{1}{b - c} \right| \right) |x| \Delta$
- (C) $\left(\frac{4}{a^2} + \frac{2}{(b - c)^2} \right)^{0.5} |x| \Delta$
- (D) $\left(\frac{2}{a^2} + \frac{1}{(b - c)^2} \right)^{0.5} |x| \Delta$

29. In the circuit shown in the following figure, the input voltage $v_i(t)$ is constant at 2 V for time $\gg 1$ s and then it changes to 1 V. The output voltage, $v_0(t)$, 2 s after the change will be

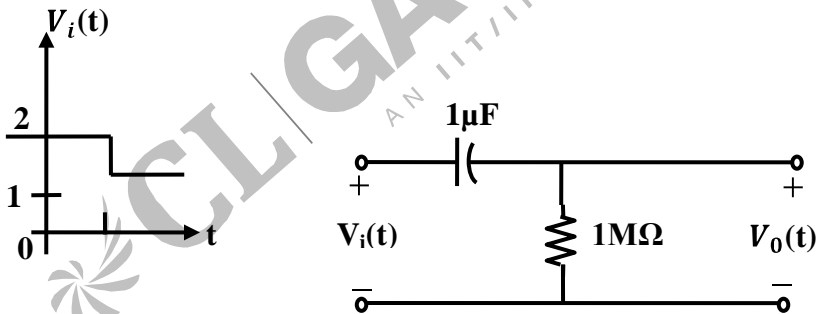

- (A) $-\exp(-2)$ V
- (B) $-1 + \exp(-2)$ V
- (C) $\exp(-2)$ V
- (D) $1 - \exp(-2)$ V
30. A metal wire has uniform cross-section A , length l , and resistance R between its two end points. It is uniformly stretched so that its length becomes αl . The new resistance is
- (A) αR
- (B) $\alpha^2 R$
- (C) $\sqrt{\alpha} R$
- (D) $e^\alpha R$

31. The secondary induced voltages of a LVDT, shown in the following figure, at null position are $\bar{v}_1 = 1.0 \text{ V} \angle 0^\circ$, $\bar{v}_2 = 1.0 \text{ V} \angle 10^\circ$ respectively. Then the null voltage of the LVDT is

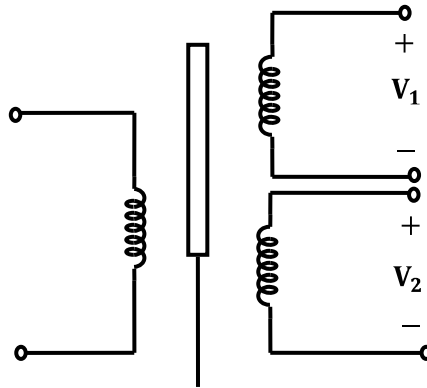

- (A) 0 V
(B) 0.014 V
(C) 0.174 V
(D) 2 V
32. A variable air gap type capacitor consists of two parallel plates: a fixed plate and a moving plate at a distance x . If a potential V is applied across the two plates, then force of attraction between the plates is related to x as
(A) $F \propto x^2$
(B) $F \propto \frac{1}{x^2}$
(C) $F \propto \frac{1}{x}$
(D) $F \propto x$
33. An accelerometer has a seismic mass of 100 microgram and natural frequency of 1 kHz. With g the acceleration due to gravity, the static sensitivity of the accelerometer in (nm/g) is
(A) 2.58 nm/g
(B) 9.81 nm/g
(C) $7.28 \times 10^2 \text{ nm/g}$
(D) $6.28 \times \text{nm/g}$
34. In the circuit shown in the following figure, the op amp has input bias current $I_b < 10 \text{ nA}$, and input offset voltage $V_{io} < 1 \text{ mV}$. The maximum dc error in the output voltage is

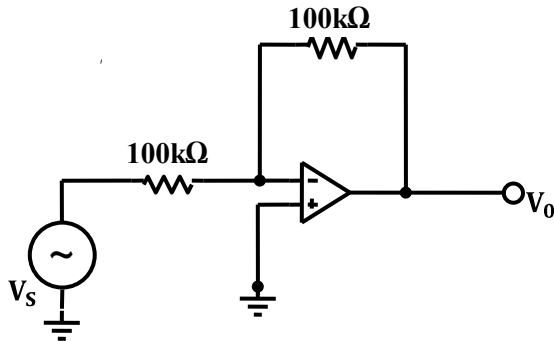

- (A) 1.0 mV
(B) 2.0 mV
(C) 2.5 mV
(D) 3.0 mV
35. The potential difference between the input terminals of an op amp may be treated to be nearly zero, if
- (A) The two supply voltages are balanced
(B) The output voltage is not saturated
(C) The op amp is used in a circuit having negative feedback
(D) There is a dc bias path between each of the input terminals and the circuit ground
36. A dual op amp instrumentation amplifier is shown below. The expression for the output of the amplifier is given by

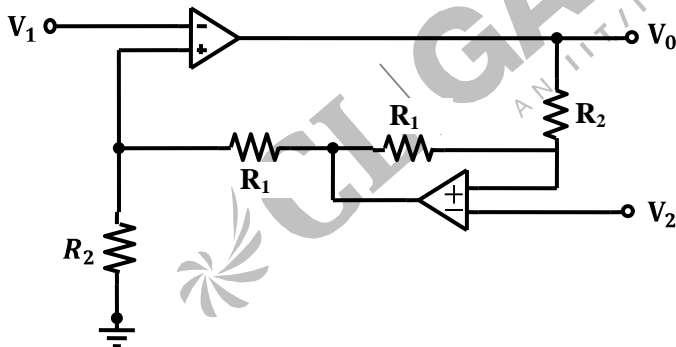

- (A) $v_0 = \left(1 + \frac{R_2}{R_1}\right)(v_2 - v_1)$
(B) $v_0 = \left(1 + \frac{2R_2}{R_1}\right)(v_2 - v_1)$
(C) $v_0 = \frac{2R_2}{R_1}(v_2 - v_1)$

$$(D) v_0 = \left(1 + \frac{2R_1}{R_2}\right)(v_2 - v_1)$$

37. An amplifier circuit is shown below. Assume that the transistor works in active region. The low frequency small-signal parameters for the transistor are $g_m = 20 \text{ mS}$, $\beta_0 = 50$, $r_o = \infty$, $r_b = 0$. What is the voltage gain,

$$A_v = \left(\frac{v_0}{v_i}\right), \text{ of the amplifier?}$$

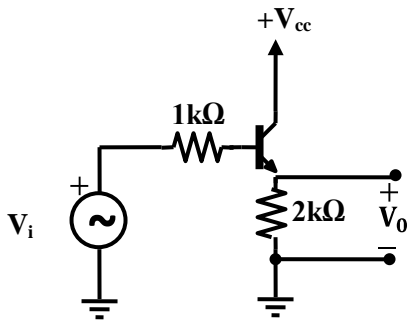

- (A) 0.967
(B) 0.976
(C) 0.983
(D) 0.998
38. The biasing circuit of a silicon transistor is shown below. If $\beta = 80$, then what is V_{CE} for the transistor ?

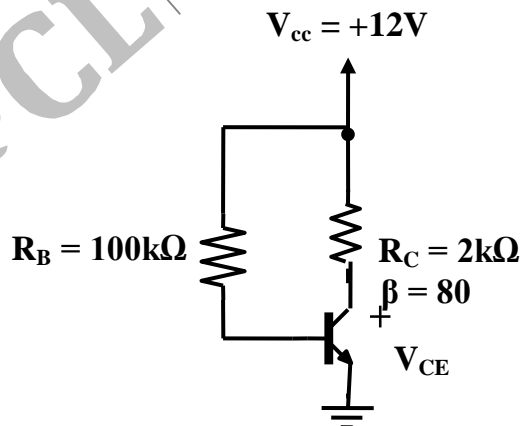

- (A) -6.08 V
(B) 0.2 V
(C) 1.2 V
(D) 6.08 V

- (A) 00-11-01-10-00
- (B) 00-01-11-10-00

- (C) 00-11-10-01-00
- (D) 00-10-01-11-00

42. An astable multivibrator circuit using a 555 IC is given in the following figure. The frequency of oscillation is

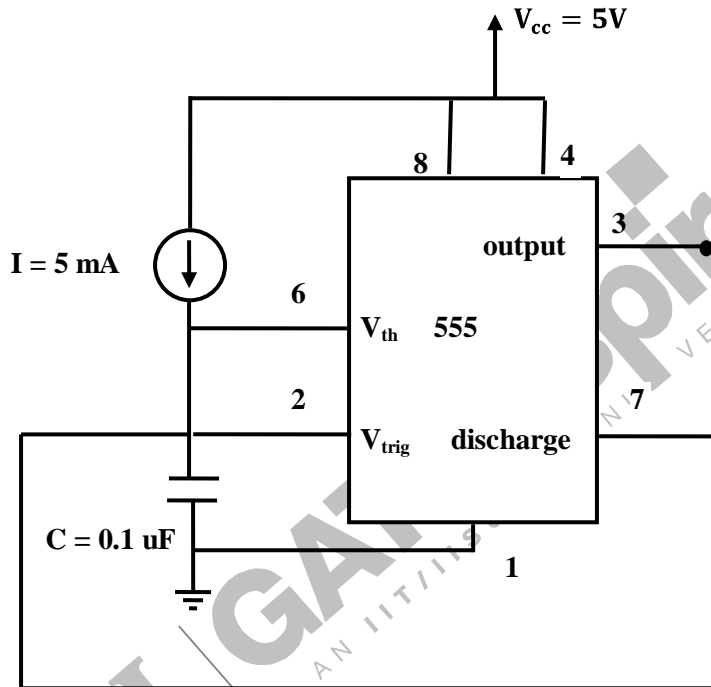

- (A) 20 kHz
- (B) 30 kHz

- (C) 40 kHz
- (D) 45 kHz

43. All the logic gates in the circuit shown below have finite propagation delay. The circuit can be used as a clock generator, if

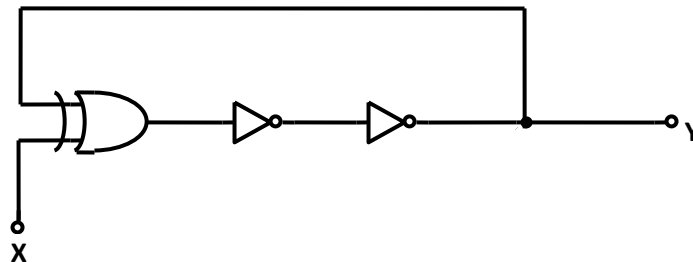

- (A) $X = 0$
- (B) $X = 1$

- (C) $X = 0$ or 1
- (D) $X = Y$

44. An 8085 assembly language program is given as follows. The execution time of each instruction is given against the instruction in terms of T-state.

Instruction	T-states
MVI B, 0AH	7T
LOOP: MVIC, 05H	7T
DCR C	4T
DCR B	4T
JNZ LOOP	10T/7T

The execution time of the program in terms of T – states is

- (A) 247 T (C) 254 T
(B) 250 T (D) 257 T
45. A number N is stored in a 4 – bit 2's complement representation as
- | | | | |
|-------|-------|-------|-------|
| a_3 | a_2 | a_1 | a_0 |
|-------|-------|-------|-------|
- It is copied into a 6 – bit register and after a few operations, the final bit pattern is
- | | | | | | |
|-------|-------|-------|-------|-------|---|
| a_3 | a_3 | a_2 | a_1 | a_0 | 1 |
|-------|-------|-------|-------|-------|---|
- The value of this bit pattern in 2's complement representation is given in terms of the original number is N as
- (A) $32 a_3 + 2N + 1$ (C) $2N - 1$
(B) $32 a_3 - 2N - 1$ (D) $2N + 1$
46. A single channel signal acquisition system with 0 – 10 V range consists of a sample – and – hold circuit with worst case drop rate of $100 \mu \text{ V/ms}$ and 10 – bit ADC. The maximum conversion time for the ADC is
- (A) $49 \mu \text{s}$ (C) 4.9 ms
(B) 0.49 ms (D) 49ms

47. Which of the following integrals provides a measure of the rapidity of change in a random variable $f(t)$?

(A) $\lim_{T \rightarrow \infty} \frac{1}{2T} \int_{-T}^{+T} f(d) dt$
 (B) $\lim_{T \rightarrow \infty} \frac{1}{2T} \int_{-T}^{+T} f^2(t) dt$
 (C) $\left[\lim_{T \rightarrow \infty} \frac{1}{2T} \int_{-T}^{+T} f^2(t) dt \right]^{1/2}$
 (D) $\lim_{T \rightarrow \infty} \frac{1}{2T} \int_{-T}^{+T} f(t) f(t + \tau) dt$

48. Given

$$x(t) * x(t) = t \exp(-2t)u(t),$$

the function $x(t)$ is

- (A) $\exp(-2t) u(t)$
 (B) $\exp(-t) u(t)$

- (C) $t \exp(-t) u(t)$
 (D) $0.5t \exp(-t) u(t)$

49. The Fourier series for a periodic signal is given as
 $x(t) = \cos(1.2\pi t) + \cos(2\pi t) + \cos(2.8\pi t)$
 The fundamental frequency of the signal is
 (A) 0.2 Hz
 (B) 0.6 Hz

- (C) 1.0 Hz
 (D) 1.4 Hz

50. If the waveform, shown in the following figure, corresponds to the second derivative of a given function $f(t)$, then the Fourier transform of $f(t)$ is

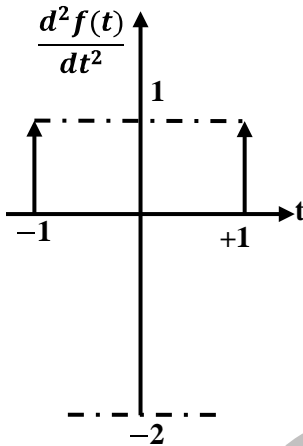

- (A) $1 + \sin \omega$
 (B) $1 + \cos \omega$
 (C) $\frac{2(1 - \cos \omega)}{\omega^2}$
 (D) $\frac{2(1 + \cos \omega)}{\omega^2}$

51. The Fourier transform of a function $g(t)$ is given as

$$G(\omega) = \frac{\omega^2 + 21}{\omega^2 + 9}$$

Then the function $g(t)$ is given as,

- (A) $\delta(t) + 2 \exp(-3|t|)$
 (B) $\cos 3\omega t + 21 \exp(-3t)$

- (C) $\sin 3\omega t + 7 \cos \omega t$
 (D) $\sin 3\omega t + 21 \exp(3t)$

52. The spectrum of a band limited signal after sampling is shown below. The value of the sampling interval is

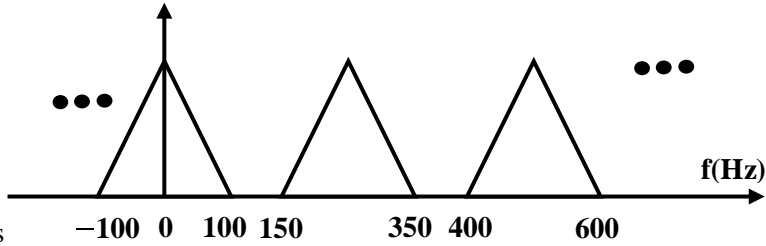

- (A) 1 ms
 (B) 2 ms
 (C) 4 ms
 (D) 8 ms

53. The magnitude of Fourier transform $X(\omega)$ of a function $x(t)$ is shown below in Fig. (a). The magnitude of Fourier transform $Y(\omega)$ of another function $y(t)$ is shown below in Fig. (b). The phases of $X(\omega)$ and $Y(\omega)$ are zero for all ω . The magnitude and frequency units are identical in both the figure. The function $y(t)$ can be expressed in terms of $x(t)$ as



- (A) $\frac{2}{3}x\left(\frac{t}{2}\right)$
 (B) $\frac{3}{2}x(2t)$
 (C) $\frac{2}{3}x(2t)$
 (D) $\frac{3}{2}x\left(\frac{t}{2}\right)$

54. In the IIR filter shown below, a is a variable gain. For which of the following cases, the system will transit from stable to unstable condition?

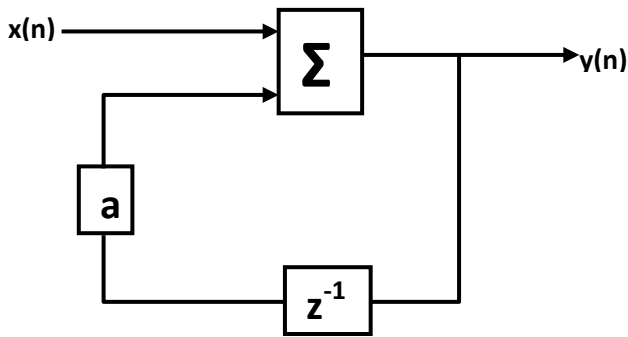

- (A) $0.1 < a < 0.5$
 (B) $0.5 < a < 1.5$

- (C) $1.5 < a < 2.5$
 (D) $2 < a < \infty$

55. A digital filter has the transfer function

$$H(z) = \frac{z^2 + 1}{z^2 + 0.81}$$

If this filter has to reject a 50 Hz interference from the input, then the sampling frequency for the input signal should be

- (A) 50 Hz
 (B) 100 Hz
 (C) 150 Hz
 (D) 200 Hz

56. A digital measuring instrument employs a sampling rate of 100 samples / second.

The sampled input $x(n]$ is averaged using the difference equation

$$y(n) = [x(n) + x(n-1) + x(n-2) + x(n-3)]/4$$

For a step input, the maximum time taken for the output to reach the final value after the input transition is

- (A) 20 ms
 (B) 40 ms
 (C) 80 ms
 (D) ∞

57. The solution of the integral equation

$$y(t) = t \exp(t) - 2 \exp(t) \int_0^t \exp(-\tau) y(\tau) d\tau$$

- (A) $\frac{1}{2} (\exp(t) - \exp(-t))$
 (B) $\frac{1}{2} (\exp(t) + \exp(-t))$
 (C) $\frac{\exp(t) - \exp(-t)}{\exp(t) + \exp(-t)}$
 (D) $\frac{\exp(-t) + \exp(t)}{\exp(-t) - \exp(t)}$

58. An unknown voltage source E_u (with negligible internal resistance) is connected to a potentiometer circuit as shown in the following figure. If the galvanometer current is $10 \mu\text{A}$ with the direction as indicated, the value of E_u is

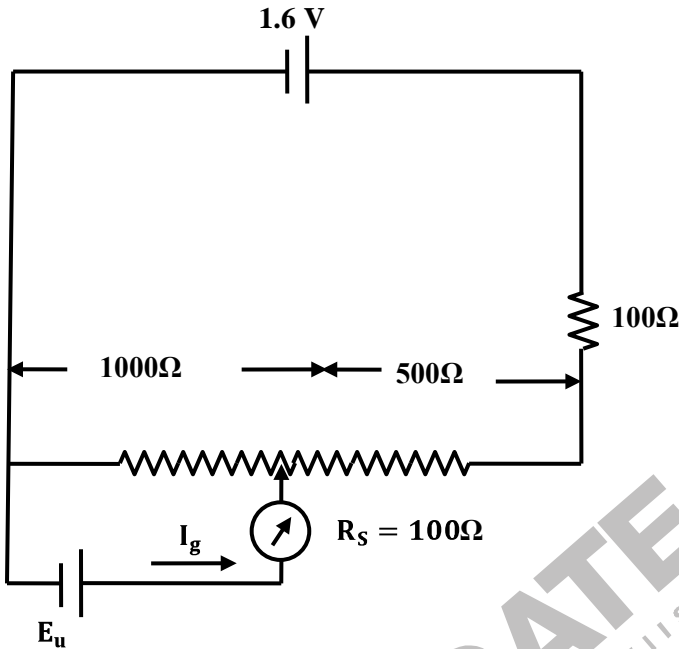

- (A) 0.9910 V
 - (B) 0.9991 V
 - (C) 1.0012 V
 - (D) 1.0048 V
59. The two-wattmeter method is used to measure power in a 3-phase, 3-wire balanced inductive circuit. The line voltage and line current are 400 V and 10 A respectively. If the load power factor is 0.866 lagging, then readings of the two wattmeters are
- (A) 6000 W and 0 W
 - (B) 5000 W and 1000 W
 - (C) 4500 W and 1500 W
 - (D) 4000 W and 2000 W
60. The voltmeter shown in the following figure has a sensitivity of $500 \Omega/\text{V}$ and a full scale of 100V. When connected in the circuit as shown, then meter reads 20 V.

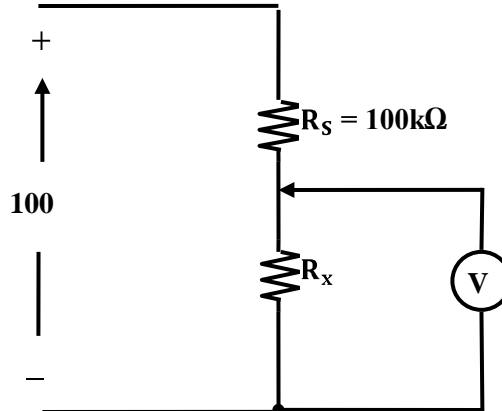

The value of R_x is

- (A) 75 k Ω
 - (B) 50 k Ω
 - (C) 25 k Ω
 - (D) 10 k Ω
61. An ac voltmeter uses the circuit shown below, where the PMMC meter has an internal resistance of 100 Ω and requires a dc current of 1 mA for full scale deflection. Assuming the diodes to be ideal, the value of R_s to obtain full scale deflection with 100 V (ac rms) applied to the input terminal would be R_s

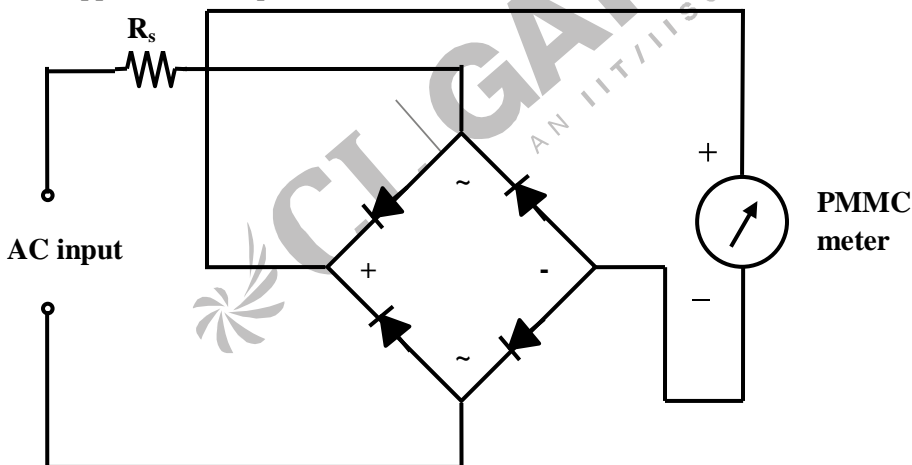

- (A) 80 k Ω
 - (B) 89 k Ω
 - (C) 89.9 k Ω
 - (D) 90 k Ω
62. Consider the AC bridge shown below. If $\omega RC = 1$ and $\frac{\Delta C}{C} < 0.01$, then ratio $\left| \frac{V_0}{V_s} \right|$ is approximately equal to

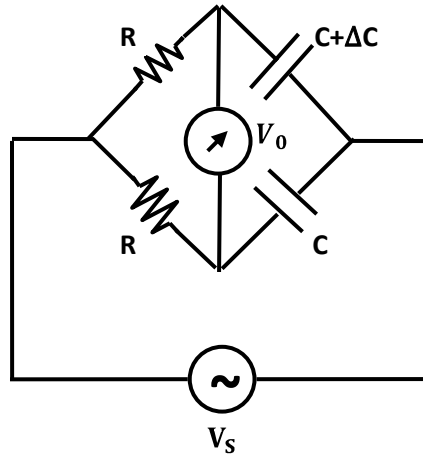

- (A) $\sqrt{1 + \frac{\Delta C}{C}}$
 (B) $\frac{2\Delta C}{C}$
 (C) $\frac{\Delta C}{C}$
 (D) $\frac{\Delta C}{2C}$

63. The transfer function of a position servo system is given as $G(s) = \frac{1}{s(s+1)}$.

A first order compensator is designed in a unity feedback configuration so that the poles of the compensated system are placed at $-1 \pm j1$ and -4 . The transfer function of the compensated system is

- (A) $\frac{s+3}{2(s+5)}$ (C) $\frac{5(s+1.6)}{s+5}$
 (B) $\frac{2s+3}{s+5}$ (D) $\frac{3(2s+3)}{s+4}$

64. The signal flow graph representation of a control system is shown below.

The transfer function $\frac{Y(s)}{R(s)}$ is computed as

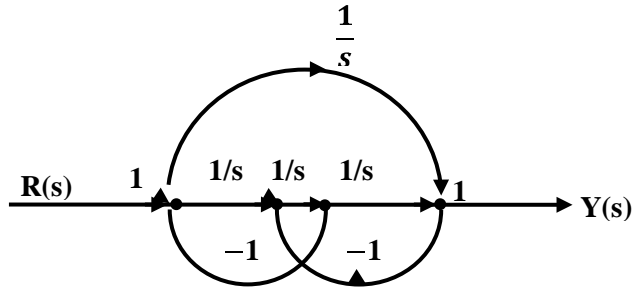

- (A) $\frac{1}{s}$
- (B) $\frac{s^2 + 1}{s(s^2 + 2)}$
- (C) $\frac{s(s^2 + 1)}{s^2 + 2}$
- (D) $1 - \frac{1}{s}$

65. The range of the controller gains (K_p, K_I) that makes the closed loop control system (shown in the following figure) stable is given as

- (A) $K_I < 0$ and $K_p < \frac{K_I}{12} - 20$
- (B) $K_I > 0$ and $K_p > 0$
- (C) $K_I < 0$ and $K_p > \frac{K_I}{12} - 20$
- (D) $K_I > 0$ and $K_p > \frac{K_I}{12} - 20$

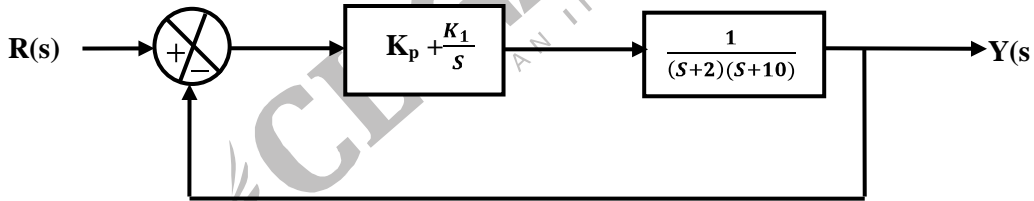

66. A unity feedback system has the following open loop frequency response :

$\omega(\text{rad/sec})$	2	3	4	5	6	8	10
$ G(j\omega) $	7.5	4.8	3.15	2.25	1.70	1.00	0.64
$\angle G(j\omega)$	-118°	-130°	140°	150°	157°	170°	-180°

The gain and phase margin of the system are

- (A) 0 dB, -180°
- (B) 3.88 dB, -170°
- (C) 0 dB, 10°
- (D) 3.88 dB, 10°

67. The root locus of a plant is given in the following figure. The root locus crosses imaginary axis at $\omega = 4\sqrt{2}$ rad/s with gain $K = 384$. It is observed that the point $s = -1.5 + j1.5$ lies in the root locus. The gain K at $s = -1.5 + j1.5$ is computed as

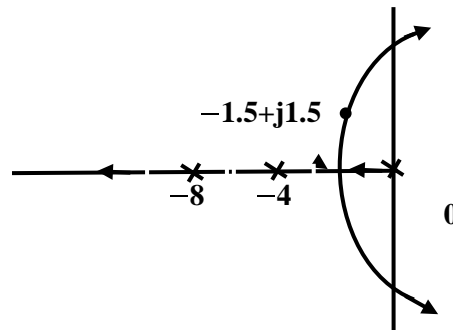

- (A) 11.3
(B) 21.2
(C) 41.25
(D) 61.2
68. A glass plate is overcoated with a thin film as shown below. The reflectance of the combination is monitored with a radiation of 600 nm wavelength. If n_g and n_f are refractive indices of the glass plate and film material respectively with $n_g > n_f$, then reflectance reaches a minimum when the geometrical film thickness equals

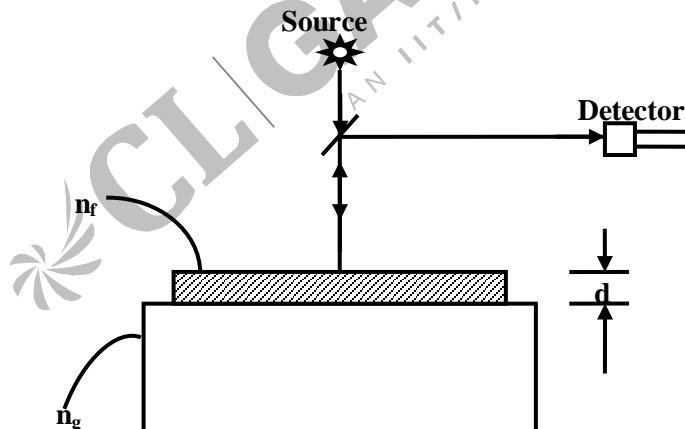

- (A) 600 nm
(B) 300 nm
(C) 150 nm
(D) 100 nm
69. The transmittance of sample solution is monitored using 500 nm wavelength. The transmittance is reduced from 100% to 10% due to addition of pollutants. As a result, the absorbance recorded by the spectrophotometer changes from

- (A) $0 \rightarrow 1$ (C) $0 \rightarrow 2$
 (B) $2 \rightarrow 1$ (D) $0 \rightarrow 10$

70. In the driven-right-leg system for reducing the common mode interference in ECG recording, the common mode voltage is sensed and connected to the right leg electrode. The desirable condition for the amplifier gain is
- (A) a large positive gain (C) a gain of 1
 (B) a large negative gain (D) a gain of -1

Common Data Questions

Common Data for Questions 71, 72, 73:

The following figure describes the block diagram of a closed loop Process control system. The unit of time is given in minute.

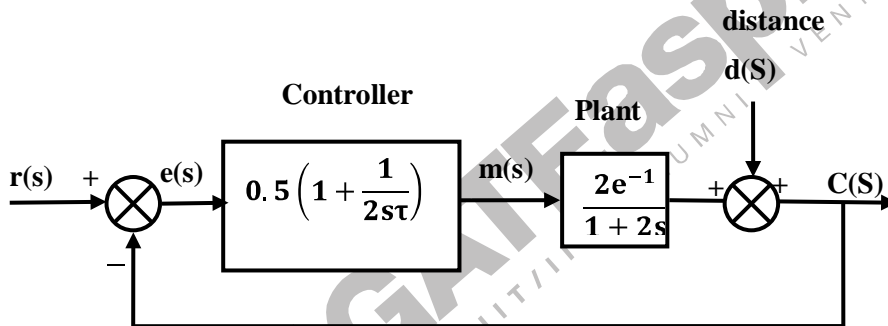

71. The digital implementation of the controller with a sampling time of 0.1 minute using velocity algorithm is
- (A) $m(k) = 0.5 \left[e(k) + 0.5 \sum_{i=1}^k e(i) \right]$ (C) $m(k) - m(k-1) = 0.5[e(k) - 0.85e(k-1)]$
 (B) $m(k) = 2.0 \left[e(k) + 2.0 \sum_{i=1}^{k-1} e(i-1) \right]$ (D) $m(k) - m(k-1) = 0.5[1.05e(k) - e(k-1)]$
72. Suppose a disturbance signal $d(t) = \sin 0.2t$ unit is applied. Then at steady state, the amplitude of the output $e(t)$ due to the effect of disturbance alone is
- (A) 0.129 unit (C) 0.528 unit
 (B) 0.40 unit (D) 2.102 unit
73. The control action recommended for reducing the effect of disturbance at the output (provided that the disturbance signal is measurable) is
- (A) cascade control (C) ratio control
 (B) P-D control (D) feedback-feedforward control

Common Data for Questions 74,75:

An R-2R ladder type DAC is shown below. If a switch status is '0', 0V is applied and if a switch status is '1', 5V is applied to the corresponding terminal of the DAC.

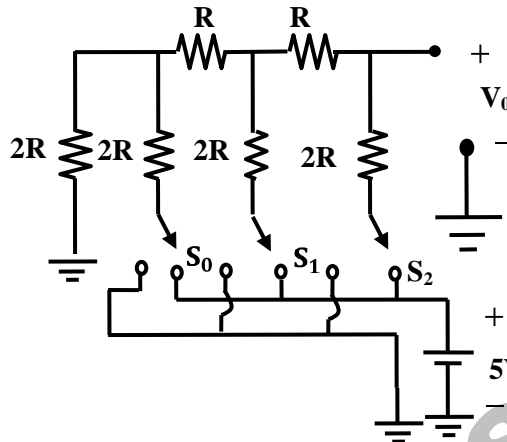

74. What is the output voltage (v_0) for the switch status $S_0 = 0, S_1 = 1, S_2 = 1$?

- (A) $\frac{5}{4}V$ (C) $\frac{17.5}{4}V$
 (B) $\frac{15}{4}V$ (D) $\frac{22.5}{4}V$

75. What is the step size of the DAC?

- (A) 0.125 V (C) 0.625 V
 (B) 0.525 V (D) 0.75 V

Linked Answer Questions : Q. 76 to Q. 85 carry two marks each.

Statement for Linked Answer Question 76 and 77:

In the circuit shown below, the current through the PMMC meter is assumed to be zero.

The ideal switch toggles between position 1 and position 2. For each position, it is connected for time $\frac{T}{2}$. Assume $R_4 C_x \ll \frac{T}{2}$ and $R_2 C_x \gg \frac{T}{2}$.

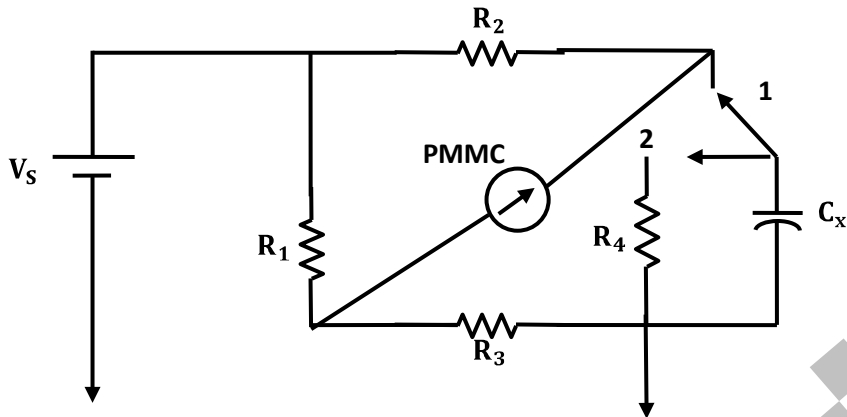

76. The capacitor C_X can be charged up to the maximum voltage
- (A) $\frac{V_s T}{2R_2 C_X}$ (C) $\frac{2V_s R_2 C_X}{T}$
 (B) $\frac{V_s T}{2R_4 C_X}$ (D) $\frac{2V_s R_4 C_X}{T}$
77. In the bridge circuit as shown in the figure above, if the PMMC meter shows null deflection, then the value of C_X is
- (A) $\frac{T}{R_4}$ (C) $\frac{T(R_3 + R_1)}{4R_2(R_3 - R_1)}$
 (B) $\frac{TR_3}{(R_1 + R_2)R_2}$ (D) $\frac{TR_3}{2R_2(R_1 - R_3)}$

Statement for Linked Answer Question 78 and 79:

A capacitive type displacement transducer consists of two triangular plates, placed side by side, with negligible gap in between them and a rectangular plate moving laterally with an uniform air gap of 1 mm between the fixed plates and the moving plate. The schematic diagram is shown below with appropriate dimension.

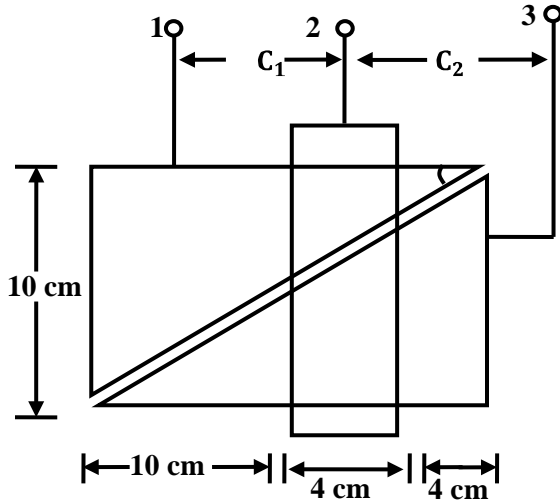

78. With the position of the moving plate shown in the figure above, the values of the capacitances C_1 and C_2 thus formed are
- (A) $C_1 = 2.14 \text{ pF}, C_2 = 1.29 \text{ pF}$ (C) $C_1 = 339 \text{ pF}, C_2 = 212 \text{ pF}$
 (B) $C_1 = 14.17 \text{ pF}, C_2 = 21.25 \text{ pF}$ (D) $C_1 = 18.16 \text{ nF}, C_2 = 23.2 \text{ nF}$
79. The above sensor is incorporated in a capacitance measuring circuit as shown in the following figure. Assuming ideal op amp, the output voltage under the conditions mentioned above is

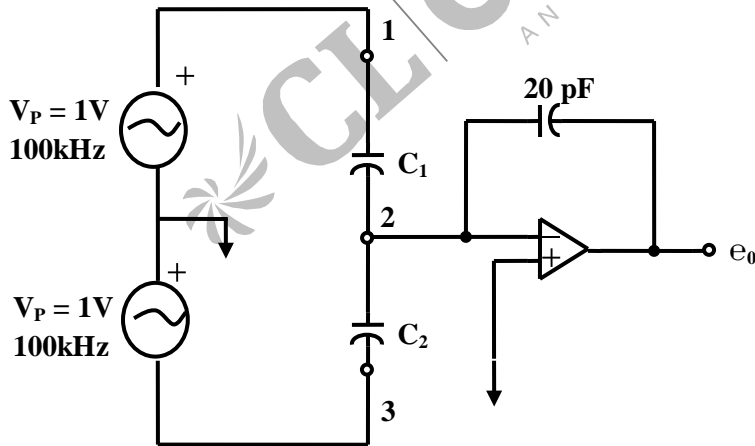

- (A) 0.012V (C) 1.23V
 (B) 0.354V (D) 2.541V

Statement for Linked Answer Questions 80 and 81:

In the Schmitt trigger circuit shown below, the Zener diodes have V_z (reverse saturation voltage) = 6 V and V_D (forward voltage drop) = 0.7 V.

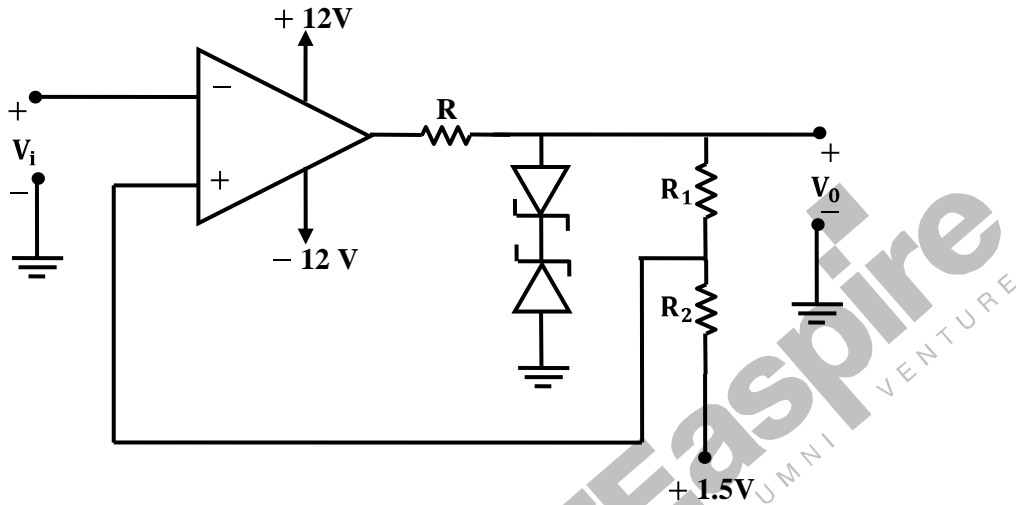

80. If the circuit has the input lower trip point (LTP) = 0 V, then value of $\frac{R_1}{R_2}$ is given as
- (A) 0.223 (B) 2.67 (C) 4.67 (D) ∞
81. The input upper trip point (UTP) of the Schmitt trigger is
- (A) 1.5 V (B) 2.1 V (C) 2.42 V (D) 6.7 V

Statement for Linked Answer Questions 82 and 83:

In a step – index optical fiber, the refractive indices of the core and the cladding are equal to 1.501 and 1.499, respectively, at the wavelength of 850 nm. The fiber is surrounded by air.

82. The numerical aperture of the optical fiber is
- (A) 0.077 (B) 0.501 (C) 1.499 (D) 1.501
83. An LED emitting light around wavelength of 850 nm is butt-coupled to the optical fiber. If the LED is assumed to be a Lambertian source, then efficiency of coupling LED light to the figure is
- (A) 7.70% (B) 1.02% (C) 0.60% (D) 0.57%

Statement for Linked Answer Questions 84 and 85:

A system of linear simultaneous equations is given as $Ax = b$ where

$$A = \begin{bmatrix} 1 & 0 & 1 & 0 \\ 0 & 1 & 0 & 1 \\ 1 & 1 & 0 & 0 \\ 0 & 0 & 0 & 1 \end{bmatrix} \text{ and } b = \begin{bmatrix} 0 \\ 0 \\ 0 \\ 1 \end{bmatrix}$$

84. The rank of matrix A is

- (A) 1 (C) 3
(B) 2 (D) 4

85. Which of the following statements is true?

- (A) x is a null vector (C) x does not exist
(B) x is unique (D) x has infinitely many values

